

# 理化学研究所脳科学総合研究センターにおけるイカ類飼育法の検討

誌名	水産増殖
ISSN	03714217
著者名	池田, 譲 櫻澤, 郁子 桜井, 泰憲 松本, 元
発行元	水産増殖談話会
巻/号	51巻4号
掲載ページ	p. 391-400
発行年月	2003年12月

農林水産省 農林水産技術会議事務局筑波産学連携支援センター  
Tsukuba Business-Academia Cooperation Support Center, Agriculture, Forestry and Fisheries Research Council  
Secretariat



## Initial Trials of Squid Rearing, Maintenance and Culture at the Brain Science Institute of RIKEN

Yuzuru IKEDA<sup>\*1,2</sup>, Ikuko SAKURAZAWA<sup>\*1,3,4</sup>, Yasunori SAKURAI<sup>\*3</sup>,  
and Gen MATSUMOTO<sup>\*1,4</sup>

( Accepted October 6, 2003 )

**Abstract:** The Brain Science Institute was established to understand the brain using by cephalopod models and employing both ethological and molecular approaches. A special facility, the Center for Squid Culture and Behavioral Research, was opened in January 1999. The initial work dealt with technical problems such as methods of squid transfer, type of aquaria used, and type of diet. Several types of closed-system aquaria are used: a large circular tank (10,000 l); a small circular tank (1,700 l); and cylindrical tanks (eight 20 l or eight of 50 l). Two species of squids (*Heterololigo bleekeri*, *Sepioteuthis lessoniana*) and cuttlefishes (*Sepiella japonica*, *Euprymna morsei*) were hatched and cultured from eggs, and wild-caught adult *H. bleekeri*, *S. lessoniana*, *Todarodes pacificus* and *Idiosepius paradoxus* were also maintained. Hatchlings of *S. lessoniana* and *S. japonica* were successfully cultured in cylindrical tanks for multiple generations. *Heterololigo bleekeri* hatchlings survived beyond 2 months in cylindrical tanks. Adult squids were successfully maintained in the large tank for the following durations: *H. bleekeri*, 78 days; *T. pacificus*, 21 days; *S. lessoniana*, 5 months; *I. paradoxus*, 54 days. A wide variety of experiments can now be undertaken using live squid and cuttlefish at this facility, but some modifications are still needed for culturing more delicate species such as *H. bleekeri*.

**Key words:** Squid; Cuttlefish; Brain science; Culture

During the latter half of the 20th century, work using squid made a considerable contribution to our understanding of neurophysiology, mainly due to experiments on the giant axon in the squid mantle (e.g., Leopold *et al.*<sup>1)</sup>). Despite its usefulness as an ideal model for experiments, keeping squid alive in captivity for long durations has been a difficult problem, and it has prevented the research from being carried out at inland laboratories. Initial successes in maintaining adult squid, *Heterololigo bleekeri* in closed seawater systems<sup>2,3)</sup> were encouraging,

and later, longer-term maintenance and rearing were successful in closed systems for loliginid species<sup>\*5</sup>, such as the California market squid, *Doryteuthis opalescens*<sup>5)</sup>, the tropical arrow squid, *D. plei*, the Atlantic long-finned squid, *D. pealei*, the brief squid, *Loliguncula brevis*<sup>6)</sup> and the oval squid, *Sepioteuthis lessoniana*<sup>7)</sup>. These rearing methods were also applied to oceanic species, and the short-finned squid, *Illex illecebrosus*<sup>8)</sup> and the Japanese common squid, *Todarodes pacificus*<sup>9,10)</sup> have been successfully maintained in a semi-closed system. In addition,

\*1 Brain Science Institute, RIKEN, Wako, Saitama 351-0198, Japan.

\*2 Present address: Department of Chemistry, Biology and Marine Science, University of the Ryukyus, Nishihara, Okinawa 903-0213, Japan. E-mail: ikeda@sci.u-ryukyu.ac.jp

\*3 Graduate School of Fisheries Sciences, Hokkaido University, Hakodate, Hokkaido 041-8611, Japan.

\*4 deceased

\*5 The genus name of loliginids followed Anderson<sup>4)</sup>.

seven consecutive generations of the European common cuttlefish, *Sepia officinalis*, have been successfully cultured in a closed system<sup>11</sup>. There are several well-established cephalopod centers that supply laboratories with cephalopods and these centers have been very important for studies of the neurophysiology and biology of squids and other cephalopods. These centers include the Stazione Zoologica (Naples, Italy), the Marine Biological Association of the U.K. (Plymouth, England), the Marine Biological Laboratory (Woods Hole, USA) and the National Research Center for Cephalopods (Galveston, USA). All of these achievements have widened the possible uses of squid as experimental animals, not only for neurophysiology, but also for other fields of comparative physiology and biology.

The Brain Science Institute (BSI) was established in 1997 at the Institute of Physical and Chemical Research (RIKEN) as an international center for brain science. The purpose of this institute is to understand the operation of the human brain through various approaches, such as physiology, anatomy, molecular biology, computer science, etc. Although vertebrates (predominantly mammals) are used as experimental animals, our group is also comparing the vertebrate brain to the squid brain. Some of the reasons for this approach are: i) squids express complicated behaviors (e.g., body patterning, elaborate courtship mating behaviors, spawning migrations) controlled by comparatively simple structures in their central nervous system<sup>12</sup>, thus they may be a suitable model for understanding the fundamental functions of the human brain. ii) squids are available nearly year-round in Japanese coastal waters, due to the common fisheries. In this context, the Center for Squid Culture and Behavioral Research at RIKEN opened in January 1999 with the initial aim of establishing a culture system for various squid and cuttlefish species and thus providing the facilities for subsequent experiments on cephalopods. We here report the progress of this new initiative and discuss the future possibilities of squid as experimental animals in brain sciences.

## Materials and Methods

### *Seawater facilities in the center for squid culture and behavioral research*

The center has three types of experimental aquaria with closed systems and two stock tanks (3,000 l, 20,000 l) for natural seawater. These are described below:

- 1) A large circular tank (CT) system (10,000 l, 4,000 mm  $\phi$ , water depth 1,000 mm) mainly used for sub-adult and adult squids maintenance (Fig. 1). The water in the large CT system is pumped through a central area of the tank bottom (800 mm  $\phi$ ) and then passed through a filter bed containing pieces of coral skeleton where seawater is both mechanically and chemically filtered. Next, the filtered seawater is passed through two routes. In the first, water is re-circulated to the main tank; in the second, water is pumped into eight cubic tanks (45 l each) for growing macroalgae (algae tank) illuminated by six 400-W metal halide lamps whose intensity and L:D cycle are automatically controlled. Water from the algae tanks is returned by gravity to the main tank. The algae tank was provided to decrease nitrate level and to maintain water quality. A catwalk is suspended above the large CT system and this serves as an observation platform (this can be moved over half of the tank surface). There is also a small CT system (1,700 l, 1,700 mm  $\phi$ , water depth 900 mm) for juvenile as well as sub-adult squid or for other purposes (e.g., behavioral experiments). The small CT system is just a miniature version of the large CT system without the algae tank. As in the large CT system, the water is pumped through a central area (385 mm  $\phi$ ) to the filter bed and then returned to the main tank. UV sterilizing systems, as well as heating and cooling units are associated with these tank systems and both temperature and water flow are monitored via a control panel. The inner wall of the tank is painted with a checked pattern to decrease the possibility of accidental collisions by the squid. Three 250-mm  $\phi$  and two 200-mm  $\phi$  windows are embedded in the walls of the large CT system

and the small CT system, respectively.

2) Cylindrical aquaria are used to incubate the squid eggs and rear the juveniles. One unit of this system consists of four 50-*l* tanks or eight 20-*l* tanks. There are two 50-*l* tank systems and one 20-*l* tank system. The water is pumped through a central area of the cylindrical aquarium to the filter bed and then returned to the cylindrical aquarium. UV sterilizing systems, as well as heating and cooling units, are associated with these tank systems.

3) A rectangular tank system (600 *l*) is used to maintain squid juveniles or prey organisms for squid. Water is pumped through a corner of

the rectangular tank to the filter bed and then returned to the rectangular tank. UV sterilizing systems, as well as heating and cooling units are associated with these tank systems.

Natural seawater in the stock tank is passed through a filter bed and circulated in the Center so that we have fresh seawater on tap at all times. This natural seawater is collected from offshore near Hachijo Island, Japan.

#### *Rearing and culturing experiments*

Adult *Heterololigo bleekeri*, *Sepioteuthis lessoniana*, and *Todarodes pacificus* were maintained in the large CT system and Japanese pygmy

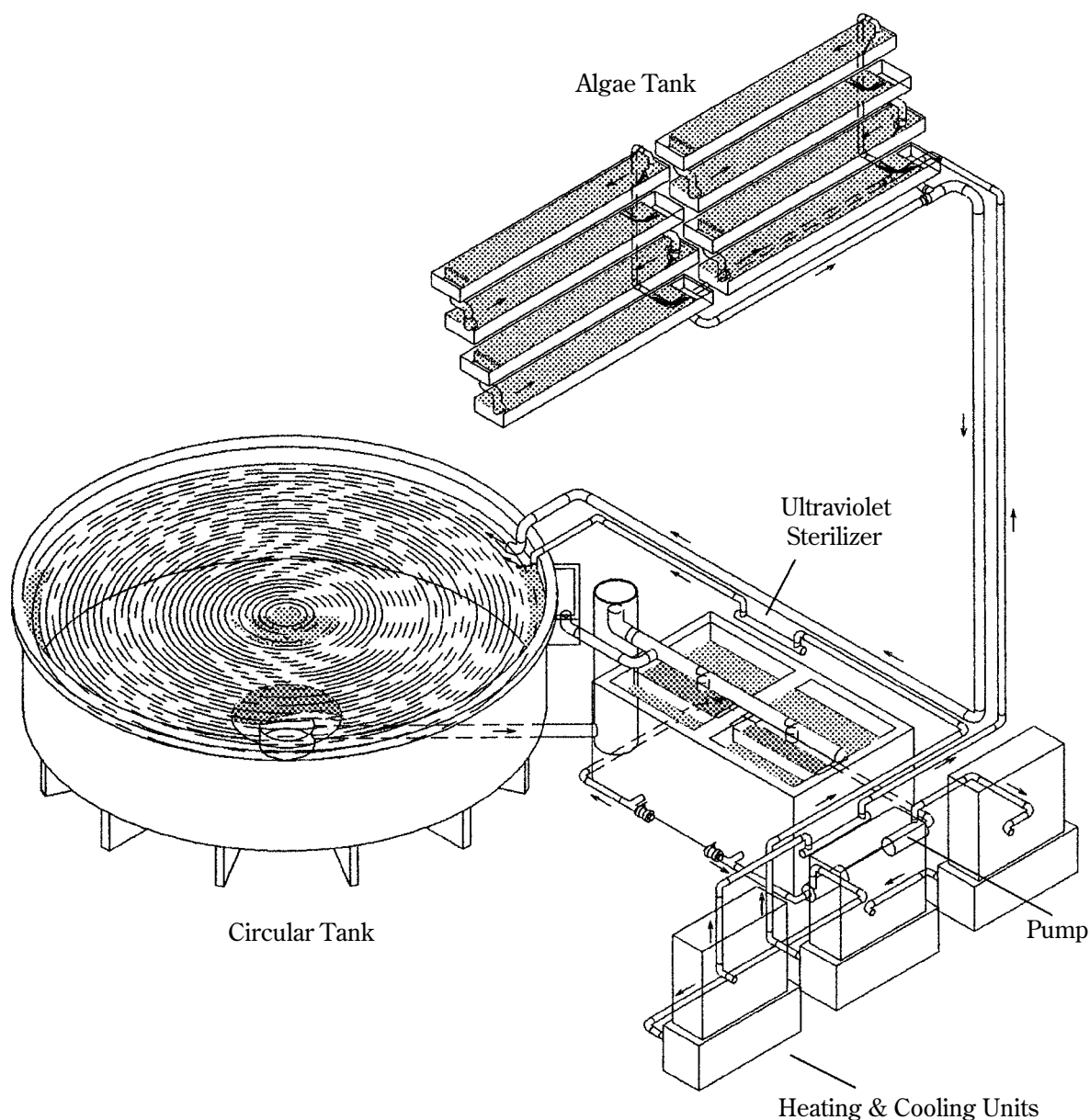

**Fig. 1.** Large circular tank (CT) system for maintenance of sub-adult and adult squids.

cuttlefish, *Idiosepius paradoxus* were maintained in the rectangular tank system. Juvenile *S. lessoniana* were reared in the small CT system and in 20-l and 50-l cylindrical aquaria. At death, mantle length (ML) of squid and cuttlefish was measured with a ruler, and body weight (BW) and weight of gonads of squid and cuttlefish were measured with an electric balance. Details of the materials, transportation and conditions of the tank systems for each species were as follows:

*Heterololigo bleekeri*: Trials were carried out in January-April 1999, and April-June 2000. *Heterololigo bleekeri* (ML 250-380 mm) were collected from the inshore waters of Miura Peninsula, Kanagawa, and transferred to the Center in a portable tank (1,000 l) with a continuous supply of air. After 3-4 hr transportation, these individuals were maintained in the large CT system (13.6-16.0 °C). The squids were fed frozen horse mackerel, *Trachurus japonicus* once a day (one horse mackerel per squid) and survival numbers, water temperature, salinity and quality of seawater (pH, ammonia, nitrite and nitrate) were continuously monitored.

*Todarodes pacificus*: Seven *T. pacificus* (ML 180-228 mm) were collected by nets set in inshore waters near Miura Peninsula, Kanagawa, transferred under cold water anesthesia<sup>10,13)</sup> for three hours and maintained in the large CT system (16.0-16.2°C). The squids were fed with frozen horse mackerel (one horse mackerel per squid) once a day.

*Sepioteuthis lessoniana*: Three *S. lessoniana* (ML 264-327 mm) were obtained from the Keikyū Aburatsubo Marine Park Aquarium and transferred in plastic bags containing seawater supplemented with O<sub>2</sub> gas. It took about three hours to transfer the squid. These individuals were maintained in the large CT system (20.4-23.0°C). In addition, eight juvenile *S. lessoniana* (their size roughly corresponding to the size of six other squid [ML 39-91 mm] collected at the same location) were collected from inshore waters near Tokushima, transferred (ca 24 hr) to the Center in plastic bags containing seawater supplemented with O<sub>2</sub> gas, and maintained in the small CT system

(23.3-23.6°C). These juveniles were fed with live freshwater fish, medaka, *Orizias latipes*, freshwater shrimp, *Palaemon paucidens*, and frozen krill, *Euphausia superba* and fish, blue sprats, *Spratelloides gracilis* 1-3 times a day. The amount of food provided was one organism per squid per feeding.

*Idiosepius paradoxus*: Five *I. paradoxus* (ML 5.0-9.8 mm, measured after fixation in 70% ethanol) were collected from inshore waters near Miura Peninsula, Kanagawa, and transferred to the Center in plastic bags containing seawater, supplemented with O<sub>2</sub> gas, and maintained in small cylinders (154 mm  $\phi$ , 2.6 l) floated using thin Styrofoam in the rectangular tank system (17.4-17.6°C). These Japanese pygmy cuttlefishes were fed live mysids, *Neomysis japonica*.

Culturing cephalopods from eggs was tried for *H. bleekeri*, *S. lessoniana*, spine-less cuttlefish, *Sepiella japonica* and bobtail squid, *Euprymna morsei* using the following methods:

*Heterololigo bleekeri*: Egg capsules were collected from an inshore site at Matsumae, Southern Hokkaido, or were spawned by captive individuals in a tank at Usujiri Fisheries Laboratory of Hokkaido University. Egg capsules were transferred to the Center in plastic bags containing seawater supplemented with O<sub>2</sub>. Egg capsules were kept in 50-l cylindrical aquaria (11.0-14.0°C). Hatched juveniles were reared in 50-l cylindrical aquaria and fed 1-3 times a day either with live mysids, *Artemia nauplii*, or sub-adult *Artemia* (BL 2-5 mm) enriched with Aquarum (Takeda Kagaku Shiryō Co., Ltd.).

*Sepioteuthis lessoniana*: Egg capsules were collected from an inshore site near Tokushima, transported to the Center in plastic bags containing seawater supplemented with O<sub>2</sub> and reared in 20-l and 50-l cylindrical aquaria (23.2-24.3°C). Hatchlings were fed with live mysids followed by frozen krill, *E. superba*.

*Sepiella japonica*: Egg capsules were collected from an inshore site near Okayama, transported to the Center in plastic bags containing seawater supplemented with O<sub>2</sub> gas, and reared in 50-l cylindrical aquaria (19.9-23.0°C). Hatchlings were fed live mysids followed by a

combination of frozen krill and blue sprat. Adult *S. japonica* ( $N=4$ , ML 163-180 mm) were collected in inshore waters of Naruto, Tokushima on May 2000, in order to compare body sizes between captive reared and wild-caught cuttlefishes. We determined the age of these wild-caught cuttlefish to be approximately one year since they got fully mature.

*Euprymna morsei*: Egg capsules were collected from an inshore site near Okayama, transported in plastic bags containing seawater supplemented with  $O_2$  gas, and reared in 50-l cylindrical aquaria (22.5-22.8°C). Hatchlings were fed with live mysids followed by post-larvae of Kuruma prawn, *Penaeus semisulcatus* and freshwater shrimp.

In all the experiments, fluorescent illumination was always present, in addition with the natural L:D day cycle through the windows of the tank facility. In trials for *E. morsei* and *S. japonica* (from June 2000), light was provided only by fluorescent illumination with a 12L:12D cycle in a windowless room. Additional fluorescent lighting was used during the feeding and maintenance procedures (i.e., feeding, cleaning, observation, etc., 1-4 hr on each occasion).

## Results

### Water quality

In the early stages of the rearing trials, when the adult *H. bleekeri* were first transferred to the large CT system, the water quality was not stable and ammonia and nitrite concentrations were high (ammonia > 5.0 mg/l, nitrite > 3.3 mg/l). The water quality gradually improved and after 3 months stabilized at acceptable levels (pH, average 7.8; ammonia 0 mg/l, nitrite < 0.3 mg/l, nitrate < 50 mg/l)<sup>5)</sup>, except for the *H. bleekeri* trials in 2000 where the ammonia concentration increased to 0.25 mg/l. The water quality of the small CT system, 20-l and 50-l cylindrical aquaria and the rectangular tank system also needed a few months before stabilizing to acceptable levels.

### Feeding, survival and growth of squids and cuttlefishes

*Heterololigo bleekeri*: In 1999, four rearing trials were performed, starting with 18-21 squids in each trial. The mortality of the adult *H. bleekeri* in the large CT system was high, mainly because of the poor water quality and some serious skin damage, during their transportation. However, a single male squid (ML 250 mm, mature at death), without skin damage, lived for 78 days in the large CT system (Fig. 2). Spawning was observed twice with undeveloped eggs (Fig. 2).

In 2000, three trials were carried out with

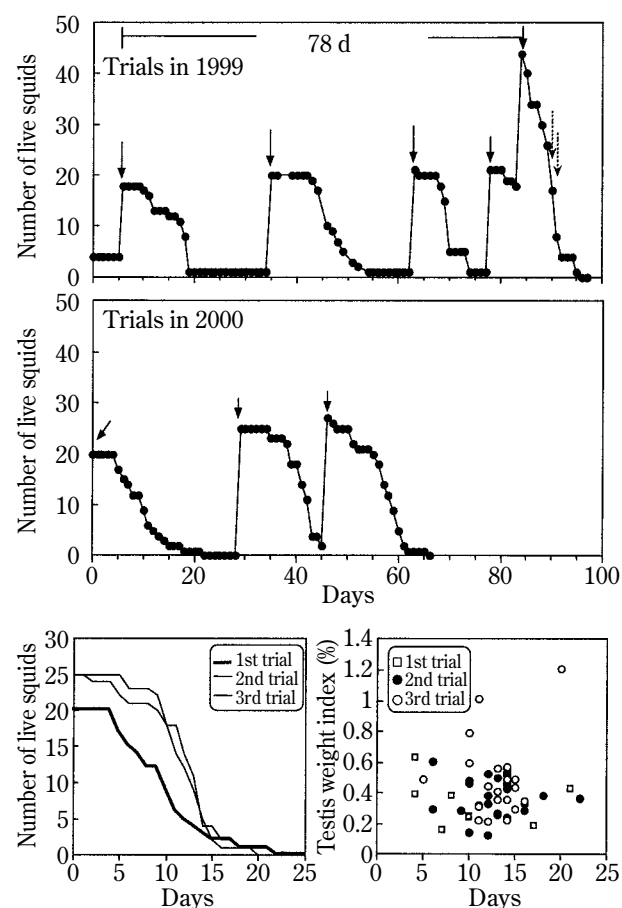

**Fig. 2.** Survivorship of adult squid, *Heterololigo bleekeri* in the large CT system. Upper and middle, trials in the years 1999 and 2000 (Arrow indicates transfer of squid. The 5th transfer was carried out when the 4th transferred squids remained in the tank, thus we included the 5th transferred squids in the 4th trail. Broken arrow indicates spawning.); bottom, comparison between survivorship and maturation process in the year 2000 trials (testis weight index, testis weight as a percent of body weight). Note, one male squid survived for 78 days in the 1999 trial.

20-25 squids in the large CT system. In each trial, the squid started dying 5 days after transfer and none survived longer than 3 weeks. The squids were mature males and even the longest surviving animal had a very thin testis with low (under 0.4%) testis weight index (testis weight as a percentage of BW, Fig. 2). The squid initially fed well on frozen horse mackerel but this decreased one week after transfer.

*Todarodes pacificus*: Five out of the seven *T. pacificus* were mature (2, 3), and did not eat enough; a common occurrence for mature individuals of this species<sup>9</sup>). Spawning occurred in the tank. Broken transparent gelatinous egg mass with ova was obtained. One female survived for 21 days after transfer.

*Sepioteuthis lessoniana*: Adults and juveniles of this species survived for 5-9 months respectively in the large CT system, the small CT system, and 20-l and 50-l cylindrical aquaria. Although they did not initially accept a frozen diet, most of them soon became accustomed to taking frozen horse mackerel and shrimp. In some occasions, *S. lessoniana* still rejected frozen horse mackerel and shrimp. However, frozen blue sprat was always acceptable as a diet, with squid even taking it from the tank bottom. Two juvenile squids (1, 1) matured in the small CT system (, ML 199 mm, 180 d after hatching; , ML 268 mm, 243 d after hatching).

*Idiosepius paradoxus*: This species lived for 20-54 days in the rectangular tank system. Spawning was observed twice for these animals, the first week and the eighth week after the cuttlefish were transferred to the tank. In the first spawning, the eggs were attached to eelgrass planted in the tank, just as Kasugai<sup>14</sup>) described for captive squid. In the second spawning, the unstructured egg mass was attached to the thin Styrofoam pieces which provided buoyancy for the small cylindrical tanks. There were only two female *I. paradoxus* (ML 5.8mm, ML 9.8 mm) in the tank—a small female, which died 13 days after spawning, and a much larger female.

Either female (or both) could have produced the initial clutches of eggs, and the larger female must have produced the eggs seen in the second spawning.

#### Culture experiments from eggs

*Heterololigo bleekeri*<sup>\*6</sup>: Hatchlings fed on *Artemia* nauplii, adult *Artemia* and mysids. To this point (August 2002), 15 animals have survived for more than 2 months in 50-l cylindrical aquaria. The growth of the juvenile squid is similar to that described by Tauchi<sup>\*7</sup> who succeeded in rearing hatchlings in tanks supplied with running natural seawater.

*Sepioteuthis lessoniana*<sup>\*8</sup>: Hatchlings actively fed on live mysids, although several weeks later cannibalism was sometimes observed when the ambient diet was poor. The juvenile squid accepted frozen shrimps at one week post-hatching, but still occasionally showed signs of rejecting this diet (Fig. 3). The growth pattern of the juvenile squid was similar to that described by Segawa<sup>15</sup>) and Lee *et al.*<sup>7</sup>). Two animals survived for 138 days, but survival duration could probably be improved if we started a larger number of hatchlings than we used initially (ca 150 hatchlings; Fig. 3). To this point (June 2002), we had succeeded in culturing this

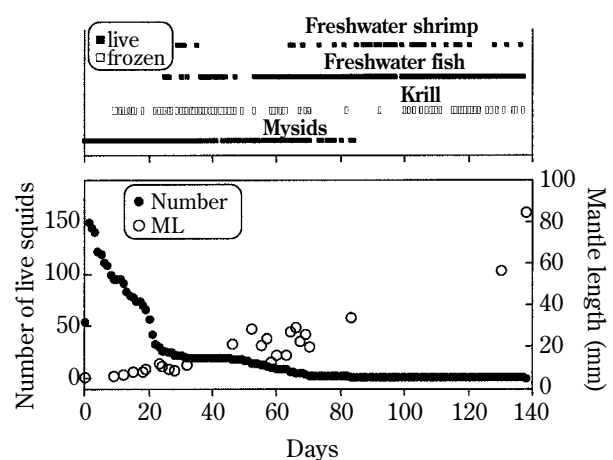

Fig. 3. Food organisms fed to oval squid, *Sepioteuthis lessoniana* and their survivorship and growth during culture experiment in the cylindrical tank in the trials in year 1999.

\*6 We will report them as original data.

\*7 Annual Report of Kanagawa Fisheries Experimental Station, pp. 26-27, 1983 (in Japanese).

\*8 We will report them as original data.

species for three consecutive generations.

*Sepiella japonica*: Hatchlings did not feed for 1-2 days post-hatching, as has been described for other sepiids (e.g., Wells<sup>16</sup>), and a high mortality was observed during this period (Fig. 4). After this, the juvenile cuttlefish actively fed on live mysids, mainly using their tentacles in the capture procedure. Like many other cuttlefishes, *S. japonica* did not swim around actively and so the 50-l cylindrical aquaria seemed sufficient to keep them healthy. Three males with ML of 70 mm, 98 mm and 110 mm, survived for 234 days, 289 days and 300 days respectively, and became mature with numerous spermatophores in the accessory gland (Fig. 4).

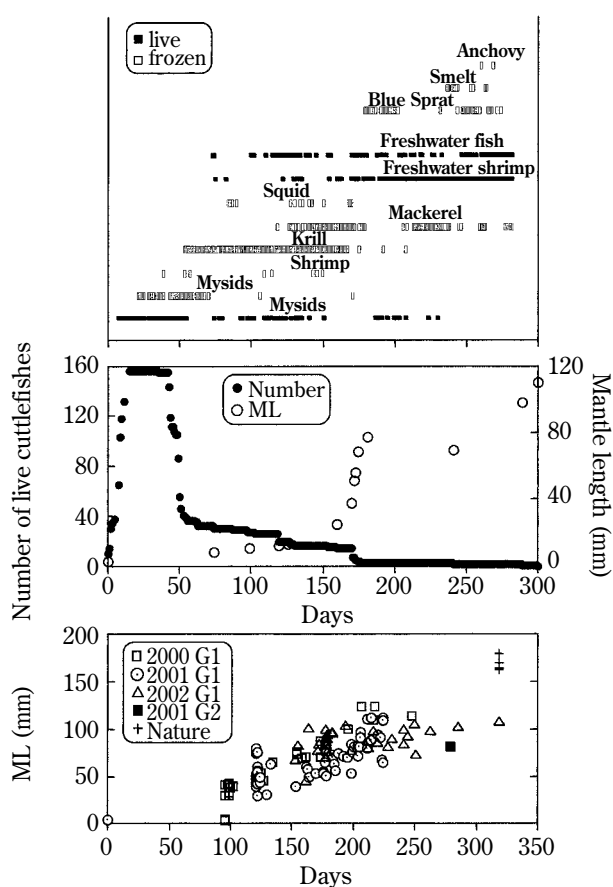

**Fig. 4.** Food organisms fed to spine-less cuttlefish, *Sepiella japonica* and their survivorship and growth during culture experiment in the cylindrical tank in the year 1999 trial (upper, middle); *S. japonica* growth during culture experiment in the year 2000, 2001 and 2002 trials (bottom). Note that newly hatched juveniles do not accept food for several days after hatching, and smaller adult size of captive *S. japonica* compared with natural population collected from inshore waters of Naruto, Tokushima on May 2000. G1, the 1st generation; G2, the 2nd generation.

phores in the accessory gland (Fig. 4). In 1999 trial, the juvenile cuttlefishes were reared in four separate 50-l cylindrical aquaria. When a cuttlefish was transferred to a different tank 5 months after hatching, this new arrival was attacked by the resident cuttlefish. This may indicate that social communities develop among the cuttlefish in each tank and that strangers are not welcome, even though they originated from the same egg mass. To this point (April 2003), we had done three culturing trials for *S. japonica*, and obtained a second generation. In these trials, we transferred juveniles of *S. japonica* from 50-l cylindrical aquaria to either the rectangular tank system or the small CT system, as the juveniles grew. We obtained mature *S. japonica* equivalent or slightly larger in size to the cuttlefish in the 1999 trial (Fig. 4).

*Euprymna morsei*: Hatchlings fed on live mysids and they also fed post-larvae of Kuruma prawn and fresh water shrimp. *Euprymna morsei* did not accept frozen shrimps and live fish such as medaka. They usually buried in coral sand and left there when feeding. They survived for 97-128 days and matured (ML 18-32 mm, BW 5.8-15.3 g, 7 individuals). One mature female possessed 240 ova and 14 ova in the ovary and oviduct, respectively, and numerous spermatophores were attached at the opening of the oviduct. A male that survived for 128 days was spent.

## Discussion

### Water quality

From the trials with *H. bleekeri* in 1999 and 2000, we could not improve water pH (near 7.6), even if about 1% of the seawater was renewed every day (which we tried in the year 2000 trial). One option for suppressing the rise in nitrite levels is to include algal cultures in the system (e.g., Yang *et al.*<sup>5</sup>). Other well-established methods such as adding sodium bicarbonate and protein skimmers must be applied to maintain pH level.

The water quality in the 20-l and 50-l cylindrical aquaria was maintained at acceptable levels throughout the experiments, mainly



through regular water changes. For example, the decrease in water pH observed when the diet of *S. japonica* in the 50-l cylindrical aquaria was changed from live mysids to frozen shrimp or fish, was corrected by an approximate 5% change in total tank volume every 2-3 days.

#### *Survival and growth*

The adult *H. bleekeri* died about 3 weeks after transfer into the large CT system in both the 1999 and the 2000 trials. Low water pH value (pH 7.6) is a possible reason for this mortality. In the culture of *D. opalescens*, Yang *et al.*<sup>5)</sup> kept the pH level at an average of 7.8 throughout the experiment. Although a high water quality is indeed important for successful rearing of squid, the maturity level of the captive squid is also an important factor in mortality, since many squids are terminal spawners<sup>17)</sup>. The *H. bleekeri* used for the trials came from the spawning population which migrates inshore in the spring at Miura Peninsula. Therefore, these animals were exhausted due to maturation. In addition, their maturation continued in captivity, as demonstrated by the thinning testes (presumably due to additional spermatogenesis) observed during the rearing period (see Fig. 2). Some of the squids in our trials appeared similar to the 'spent', or exhausted, spawning individuals of *T. pacificus* observed in captivity by Ikeda *et al.*<sup>9)</sup>. Collections of juvenile or sub-adult squid will be needed for the long-term rearing for *H. bleekeri* in our system. However, another point that must be addressed is the "quality" of transportation from the coast to the RIKEN facility. In the 1999 trial, one male *H. bleekeri*, which was delivered in extremely good condition, survived for 78 days in the large CT system. This demonstrates that the collection and transportation process is very important in determining the success of the long-term rearing and maintenance of squid<sup>6,18,19)</sup>.

The duration of maintenance for *T. pacificus* in the present study (21 days) was shorter than the times obtained previously in semi-closed seawater systems (over 2 months)<sup>9,10)</sup>. However, considering that the present study used a completely closed seawater system, 21 days was not

unreasonable for this oceanic species, which is considered difficult to maintain in captivity<sup>20)</sup>.

*Sepioteuthis lessoniana* is an ideal animal for culture as Lee *et al.*<sup>7)</sup> have already succeeded in culturing this species for three generations in a closed seawater system. In the present trial, there were no serious problems in culturing this species, both in 20-l and 50-l cylindrical aquaria and in the large CT system. *Sepioteuthis lessoniana* is a common species in Japanese waters, and thus provides a good candidate as an experimental animal at our Center. The various body pattern displays of this species<sup>12,21,22)</sup> make it attractive for ethological studies of communication in squid.

We were quite successful in rearing *S. japonica*. The 50-l cylindrical aquaria are eminently suitable for long-duration culturing of cuttlefish, since these animals do not actively swim around in the tank. Also, *S. japonica* is very tame and would even take frozen food directly from the hand. Teramura<sup>23)</sup> reported the culture of *S. japonica* at Inubozaki Marine Park Aquarium. From his study, cultured *S. japonica* achieved cuttlebone lengths (CL) of 10 mm at 1 month, 20-40 mm at 2-3 months, 50 mm at 4 months and they matured at 90 mm at 6 months. Cuttlebone growth of *S. japonica* was similar to that observed by Teramura<sup>23)</sup> but maturity was delayed in our trial to about 8-10 months. One difference between our culture condition and that of Teramura<sup>23)</sup> was stock density. The stock density of 5-10 cuttlefishes in 1,000 × 1,000 × 600-mm aquarium used by Teramura<sup>23)</sup> was much lower than that used here. Differences in the type of diet used in these two trials may also have affected the maturation process of the cuttlefish. Compared with a natural population of *S. japonica* ( $n=4$ , ML 163-180 mm), our animals seem to be of small adult size (ML 70 mm at 234 days, 98 mm at 289 days, 110 mm at 300 days of initial trial). Transferring animals to much larger tanks (e.g., the large CT system) as they grow may be one way to make cuttlefish grow to a larger size. Actually, Forsythe *et al.*<sup>11)</sup> produced cultured *S. officinalis* equally large to those from natural populations.

Jackson<sup>24)</sup> estimated that the life span of

pygmy cuttlefish, *Idiosepius pygmaeus* will be 1.5-2 months. This short life span of *Idiosepius* species is an advantage in genetic studies, and research on cultured *I. paradoxus* may therefore be of considerable use. Natsukari<sup>25)</sup>, who observed spawning behavior of *I. paradoxus* in captivity, suggested that the female dies soon after spawning. However, in our trial, two probable spawning females survived for some time after the egg mass was produced. Furthermore, the present observations suggested that a single female can spawn several times, with an interval of 1 month between episodes.

In captivity, *Euprymna scolopes*, a close relative of *E. morsei*, attained maturity by 60 days post-hatching, and its life cycle was about 80 days (the longest-survivor was 139 days of age)<sup>26)</sup>. This seems similar to our trial for *E. morsei*. It is also interesting that *E. morsei* preferred crustacean diets, which was also seen for *E. scolopes* in captivity<sup>26)</sup> and *E. scolopes* in nature<sup>27)</sup>. Similar to *I. paradoxus*, short life span of *E. morsei* may be an advantage in various aspects of biological research.

#### *Toward brain science applications*

We have established that long-term rearing of *S. lessoniana* and *S. japonica* is possible in our Center. In contrast to these species, we did not succeed in maintaining adult *H. bleekeri* or *T. pacificus* for long periods. However, by obtaining juvenile or immature individuals of these species, it is likely that we can greatly improve the long-term rearing of these species. We have demonstrated here that rearing, maintenance and culture of squid and cuttlefish in closed sea-water systems is possible at an inland institute. With this success, we can plan physiological as well as behavioral studies using squid and cuttlefish at any stages of their life history.

#### **Acknowledgments**

We acknowledge M. Ichikawa, H. Yamada, K. Ohkawa, H. Ishii, M. Kato, S. Shigeno, W. Godo, H. Kabasawa, T. Sato, M. Sekimoto, M. Sekifuji, Y. Ueta, N. Akiyama, H. Yoshino and S. Enokita for their kind cooperation and advice to

our project and S. Chiba for drawing figure 1. We thank R. Williamson and F. E. Anderson for their reading of the manuscript. We are grateful to the members at Brainway Group of BSI for their help throughout the project. Financial support was provided by RIKEN. We dedicate this paper to the memories of I. Sakurazawa and G. Matsumoto.

#### **References**

- 1) Leopold, P. L., J. W. Lin, and M. Sugimori (1995): The nervous system of *Loligo pealei* provides multiple models for analysis of organelle motility, in "Cephalopod Neurobiology" (ed. by N. J. Abbott, R. Williamson, and L. Maddock), Oxford University Press, Oxford, pp. 15-34.
- 2) Matsumoto, G. (1976): Transportation and maintenance of adult squid (*Doryteuthis bleekeri*) for physiological studies. *Biol. Bull.* **150**, 279-285.
- 3) Matsumoto, G. and J. Shimada (1980): Further improvement upon maintenance of adult squid (*Doryteuthis bleekeri*) in a small circular and closed-system aquarium tank. *Biol. Bull.* **159**, 319-324.
- 4) Anderson, F. E. (2000): Phylogenetic relationships among loliginid squids (Cephalopoda: Myopsida) based on analysis of multiple data sets. *Zool. J. Linn. Soc.* **130**, 603-633.
- 5) Yang, W. T., R. F. Hixon, P. E. Turk, M. E. Krejci, W. H. Hulet, and R. T. Hanlon (1983): Growth, behavior and sexual maturation of the market squid, *Loligo opalescens*, cultured through the life cycle. *Fish. Bull.* **84**, 771-798.
- 6) Hanlon, R. T., R. F. Hixon, and W. H. Hulet (1983): Survival, growth, and behavior of the loliginid squids *Loligo plei*, *Loligo pealei*, and *Lolliguncula brevis* (Mollusca: Cephalopoda) in closed sea water systems. *Biol. Bull.* **165**, 637-685.
- 7) Lee, P. G., P. E. Turk, W. T. Yang, and R. T. Hanlon (1994): Biological characteristics and biomedical applications of the squid *Sepioteuthis lessoniana* cultured through multiple generations. *Biol. Bull.* **186**, 328-341.
- 8) O'Dor, R. K., R. D. Durward, and N. Balch (1977): Maintenance and maturation of squid (*Illex illecebrosus*) in a 15 meter circular pool. *Biol. Bull.* **153**, 322-335.
- 9) Ikeda, Y., Y. Sakurai, and K. Shimazaki (1993): Maturation process of the Japanese common squid, *Todarodes pacificus* in captivity, in "Recent Advances in Cephalopod Fishery Biology" (ed. by T. Okutani, R. K. O'Dor and T. Kubodera), Tokai University Press, Tokyo, pp. 179-187.
- 10) Sakurai, Y., Y. Ikeda, M. Shimizu, and K. Shimazaki (1993): Feeding and growth of captive adult Japanese common squid, *Todarodes pacificus*, measuring initial body size by cold anesthesia, in "Recent Advances in Cephalopod Fishery Biology" (ed. by T. Okutani, R. K.

- O'Dor, and T. Kubodera), Tokai University Press, Tokyo, pp. 467-476.
- 11) Forsythe, J. W., R. H. DeRusha, and R. T. Hanlon (1994): Growth, reproduction and life span of *Sepia officinalis* (Cephalopoda: Mollusca) cultured through seven consecutive generations. *J. Zool. Lond.* **233**, 175-192.
  - 12) Hanlon, R. T. and J. B. Messenger (1996): Cephalopod Behaviour. Cambridge University Press, Cambridge, 232 pp.
  - 13) Bower, J. R., Y. Sakurai, J. Yamamoto, and H. Ishii (1999): Transport of the ommastrephid squid *Todarodes pacificus* under cold-water anesthesia. *Aquaculture*, **170**, 127-130.
  - 14) Kasugai, T. (2000): Reproductive behavior of the Pygmy cuttlefish *Idiosepius paradoxus* in an aquarium. *Venus*, **59**, 37-44.
  - 15) Segawa, S. (1987): Life history of the oval squid *Sepioteuthis lessoniana*, in Kominato and adjacent waters of central Honshu, Japan. *J. Tokyo Univ. Fish.* **74**, 67-105.
  - 16) Wells, M. J. (1958): Factors affecting reactions to *Mysis* by newly hatched *Sepia*. *Behaviour*, **13**, 96-111.
  - 17) Mangold, K. (1987): Reproduction, in "Cephalopod Life Cycles, vol. II: Comparative Reviews" (ed. by P. R. Boyle), Academic Press, London, pp. 157-200.
  - 18) Boletzky, S. v. and R. T. Hanlon (1983): A review of the laboratory maintenance, rearing and culture of cephalopod molluscs. *Mem. Nat. Mus. Victoria*, **44**, 147-187.
  - 19) Hanlon, R. T. (1990): Maintenance, rearing and culture of teuthoid and sepioid squids, in "Squid as Experimental Animals" (ed. by D. Gilbert, H. Adelman and J. M. Arnold), Plenum Press, New York, pp. 35-62.
  - 20) Hanlon R. T. (1987): Mariculture, in "Cephalopod Life Cycles, vol. II: Comparative Reviews" (ed. by P. R. Boyle), Academic Press, London, pp. 291-305.
  - 21) Moynihan, M. (1985): Communication and Noncommunication by Cephalopods. Indiana University Press, Bloomington. 141 pp.
  - 22) Boal, J. G. and S. A. Gonzalez (1998): Social behaviour of individual oval squids (Cephalopoda, Teuthoidea, Loliginidae, *Sepioteuthis lessoniana*) with a captive school. *Ethology*, **104**, 161-178.
  - 23) Teramura K. (1990): *Sepiella japonica*, in "Reproduction of Marine Fish" (ed. by K. Suzuki and S. Takashima), Midorishobo, Tokyo, pp. 230-232 (in Japanese).
  - 24) Jackson, G. D. (1988): The use of statolith microstructures to analyze life-history events in the small tropical cephalopod *Idiosepius pygmaeus*. *Fish. Bull.* **87**, 265-272.
  - 25) Natsukari, Y. (1970): Egg-laying behavior, embryonic development and hatched larva of the pygmy cuttlefish, *Idiosepius pygmaeus paradoxus* Ortmann. *Bull. Fac. Fish. Nagasaki Univ.*, **30**, 15-29 (in Japanese).
  - 26) Hanlon, R. T., M. F. Claes, S. E. Ashcraft, and P. V. Dunlap (1997): Laboratory culture of the sepiolid squid *Euprymna scolopes*: a model system for bacteria-animal symbiosis. *Biol. Bull.*, **192**, 364-374.
  - 27) Singley, C. T. (1983): *Euprymna scolopes*, in "Cephalopod Life Cycles, vol. I: Species Accounts" (ed. by P. R. Boyle), Academic Press, London, pp. 69-74.

## 理化学研究所脳科学総合研究センターにおけるイカ類飼育法の検討

池田 譲・櫻澤郁子・桜井泰憲・松本 元

理化学研究所脳科学総合研究センターでは、脳を知るためのモデル動物としてイカ類に注目し、行動学的および分子生物学的研究を行うために内陸部初のイカ長期飼育施設を開設した。これに伴い、各種イカ類の輸送、水槽の種類、餌料などについて飼育実験より検討した。飼育には閉鎖循環系の大型円形水槽(10,000 l)、小型円形水槽(1,700 l)、マルチハイデンス水槽(20 l-8基, 50 l-8基)、角形水槽(600 l)を用いた。ヤリイカ, アオリイカ, シリヤケイカ, ミミイカを卵から飼育するとともに、ヤリイカ, アオリイカ, スルメイカ, ヒメイカ各成体をそれぞれ畜養した。その結果、シリヤケイカおよびアオリイカの累代飼育に、また、ヤリイカの2か月間の孵化飼育にそれぞれ成功した。閉鎖系における3種成体の畜養も可能でありスルメイカでは産卵も観察された。これらに基づき各種ごとの飼育の問題点について考察した。